

Example examination question 1_2:

A continuous beam of 10 m length is simply supported at 0, 5, and 10 m from the left end. A load (use 1000 kN) is applied vertically at midspan of the first bay.

- a)
 - a. Use DrBeam to check if the parameters as shown in the second diagramme of HSC page 5-161 (copy included below) are correct.
 - b. Move the concentrated load along the beam and observe the envelopes for deflection, shear, and bending moment. Do you notice where the envelope plot of DrBeam is deficient?
 - c. Use the Envelope Inspector to observe the values for the deflection envelope. Why do the locations of maximum and minimum deflection not coincide?
- b)
 - a. Use DrBeam to check if the parameters as shown in the second diagramme of HSC page 5-159 (copy included below) are correct.
 - b. The total loads are equal in both cases. What difference can you observe in the deflection, shear, and moment distribution of the two cases a) and b)?
- c)
 - a. Use DrBeam to check if the parameters as shown in the third diagramme of HSC page 5-160 (copy included below) are correct. What is the particular parameter to watch in this case?

Case a):

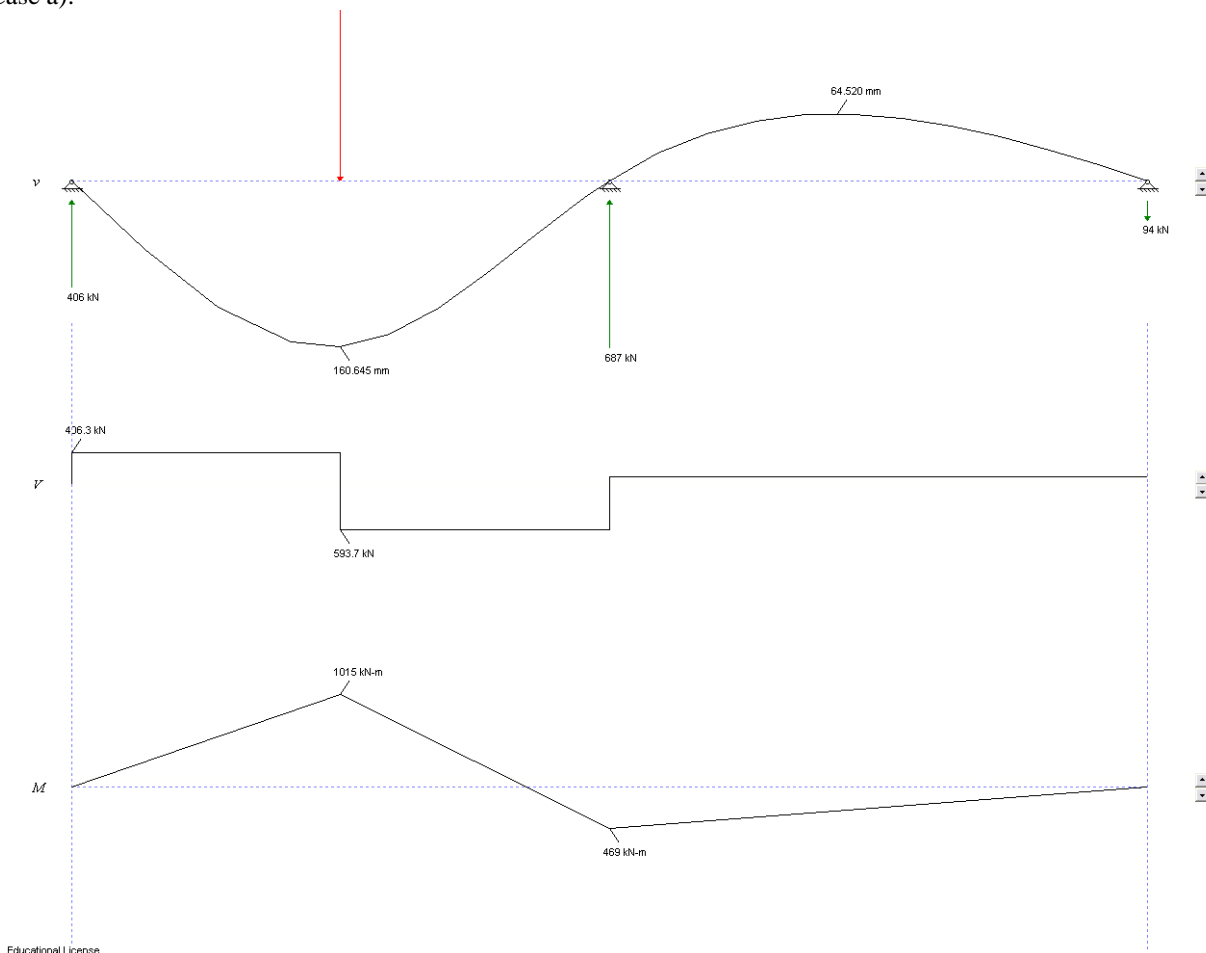

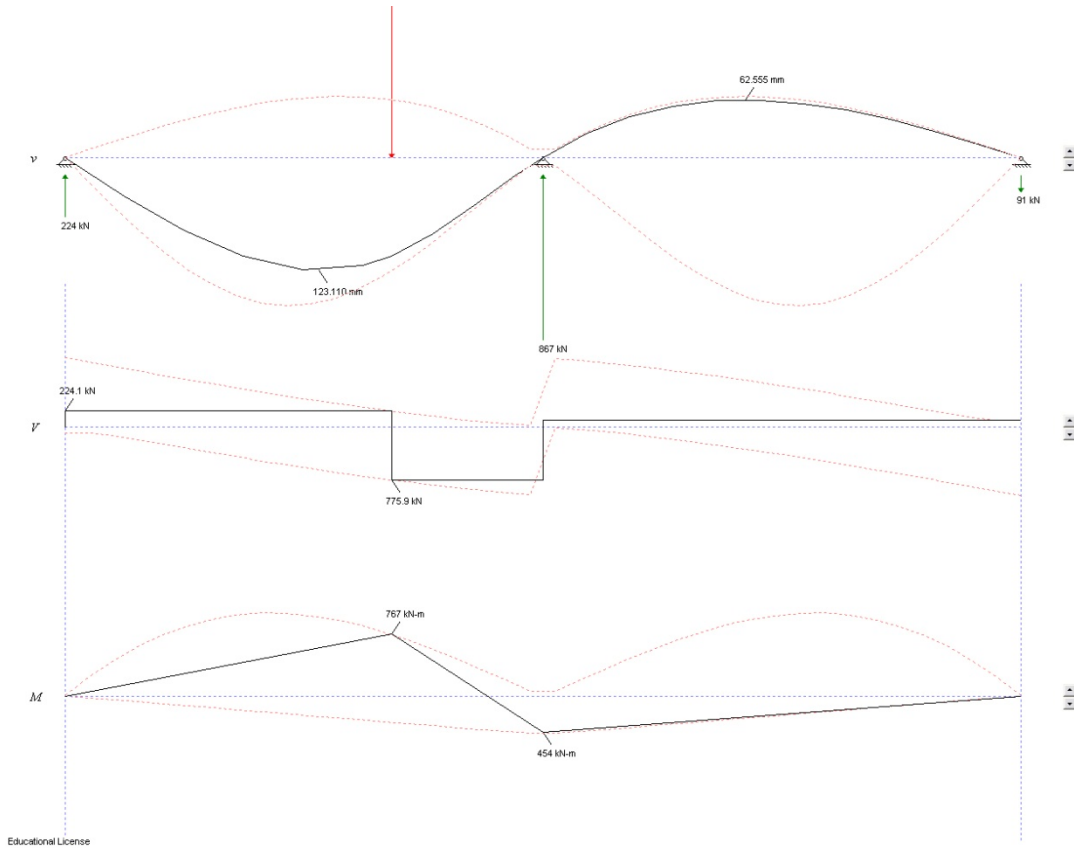

Case b):

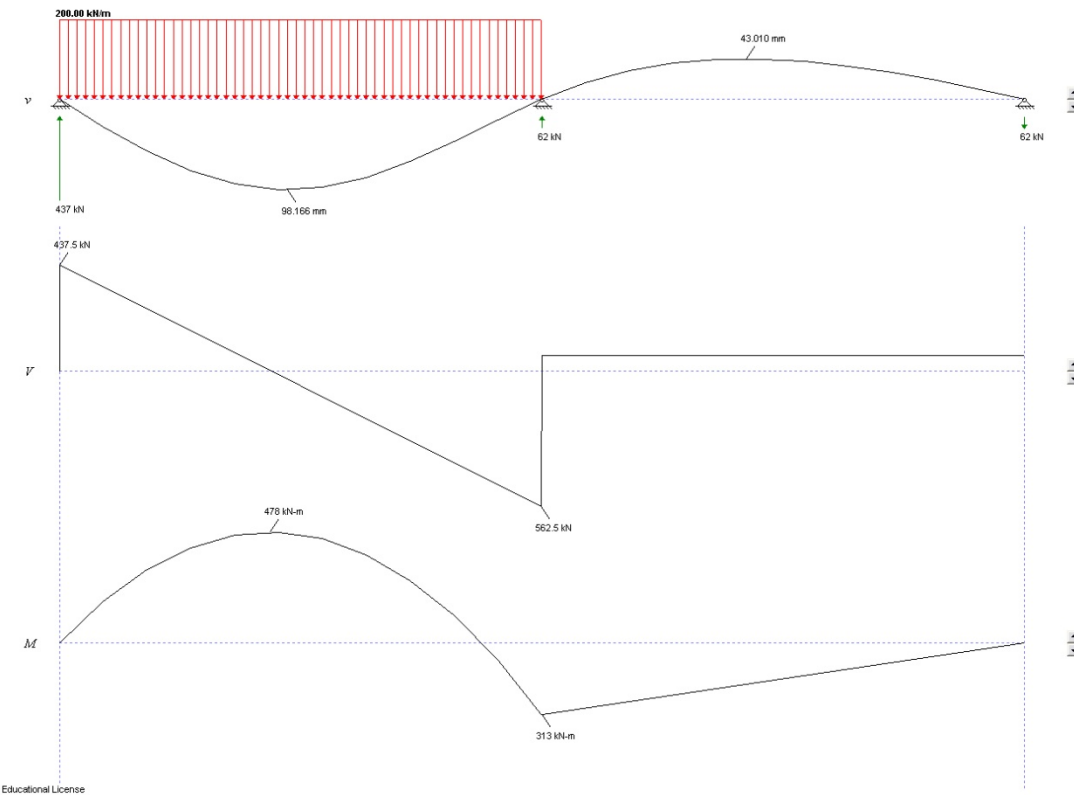

MOMENTS, REACTIONS Equal Span Continuous Beams CENTRAL POINT LOADS

Moment = Coefficient x W x L
 Reaction = Coefficient x W
 Where: W = The concentrated load on one span
 L = Length of one span

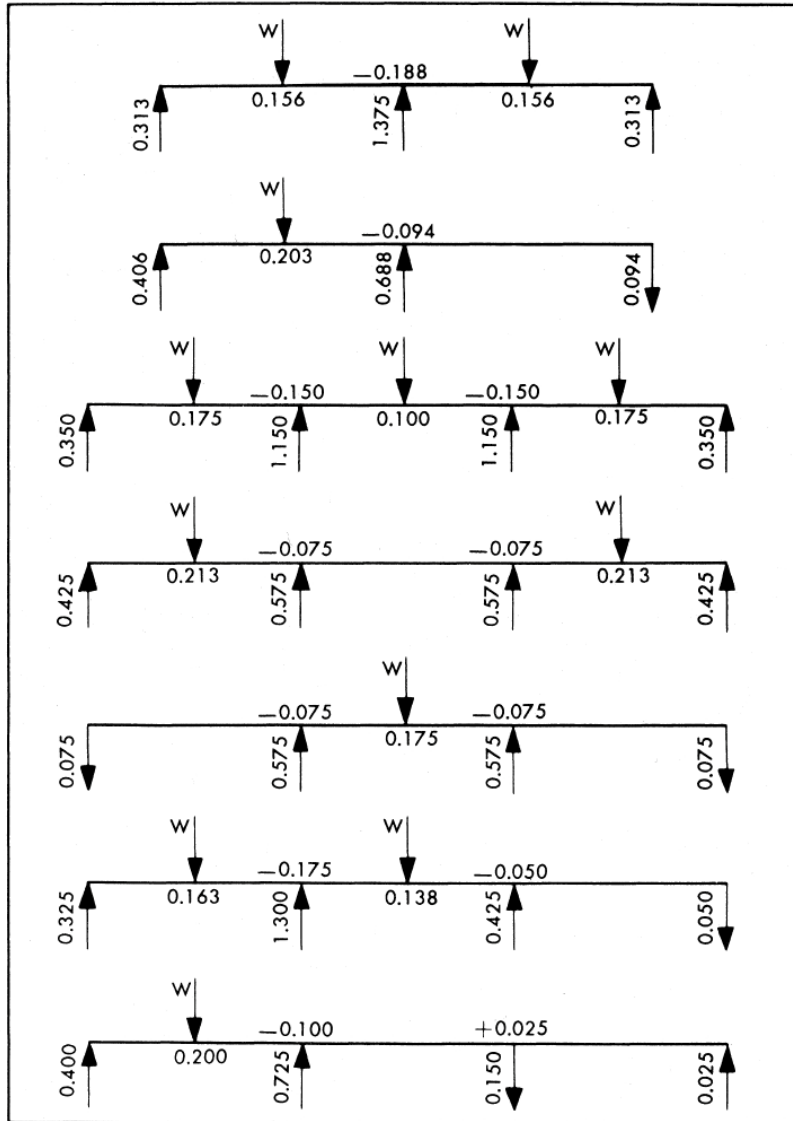

MOMENTS, REACTIONS Equal Span Continuous Beams UNIFORMLY DISTRIBUTED LOADS

Moment = Coefficient x W x L
 Reaction = Coefficient x W
 Where: W = Total uniformly distributed load on one span
 L = Length of one span

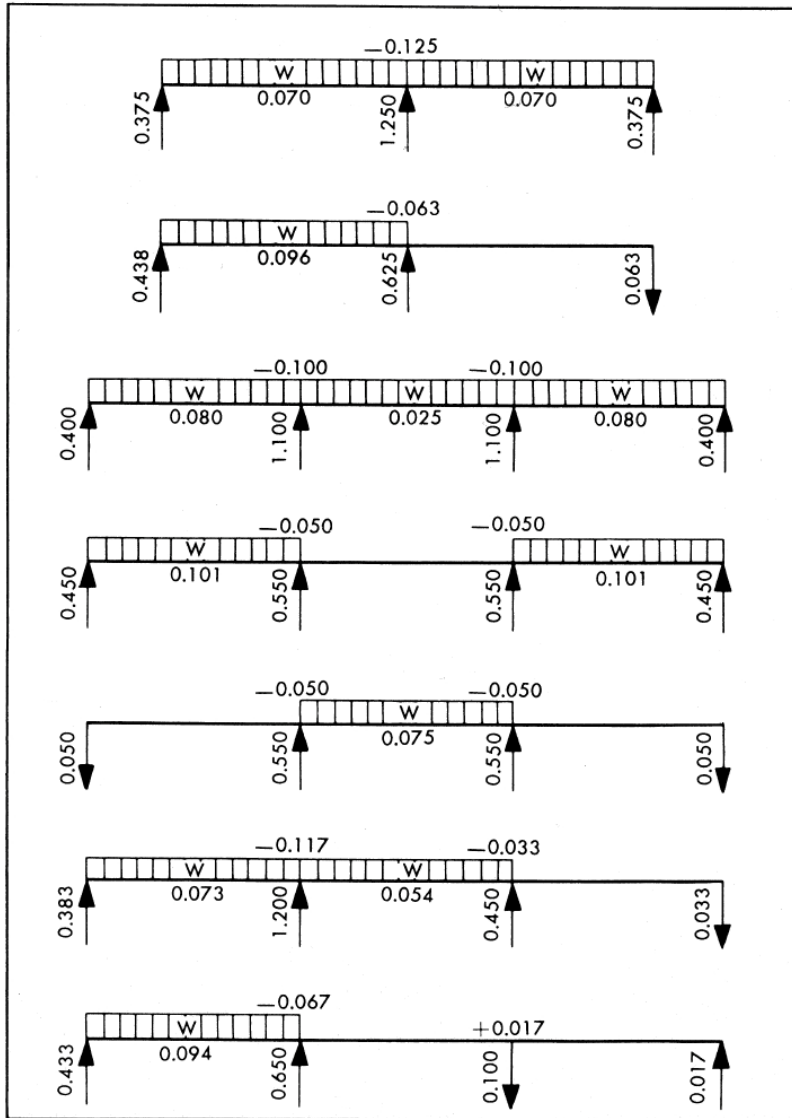

MOMENTS, REACTIONS Equal Span Continuous Beams

UNIFORMLY DISTRIBUTED LOADS

Moment = Coefficient x W x L
 Reaction = Coefficient x W
 Where: W = Total uniformly distributed load on one span
 L = Length of one span

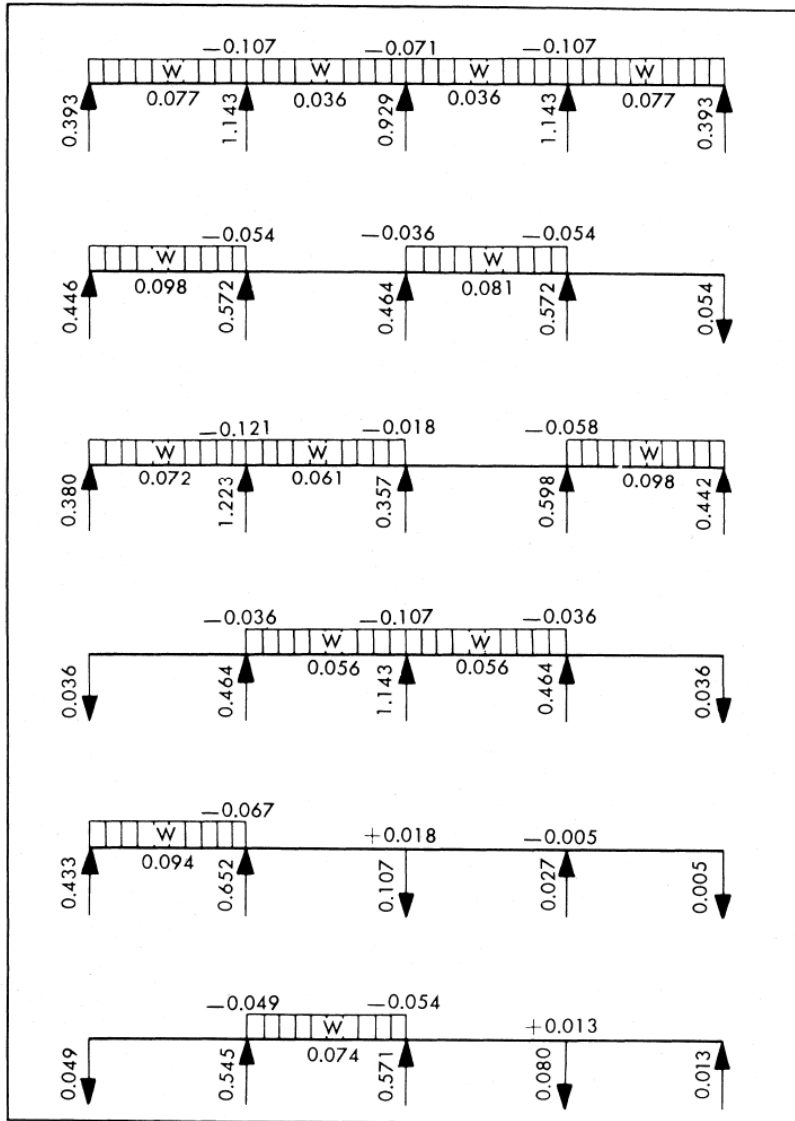

5-160

CISC Handbook of Steel Construction